



# USER'S MANUAL

**For Model:RC  
Date:2024.1**

**XL20240101**

**Read this manual completely before riding your electric scooter**

## Preface

Please read the manual carefully before use. Do not operate the electric motorcycle until you fully understand its characteristics. Familiarizing yourself with safety knowledge, proper usage, storage, and maintenance methods can minimize malfunctions, maintain optimal performance, and extend the lifespan of your electric motorcycle. The data, descriptions, and specifications indicated in this manual are based on the latest design of the vehicle, adhering to the current valid product standards. Our company reserves the right to continuously improve our products without prior notice. In case of discrepancies between the manual and the actual product, the latter shall prevail. Your valuable feedback on our vehicle's design, manufacturing, and quality will be sincerely appreciated, and please inform us promptly for further improvements. Our authorized service stations across various locations are here to provide you with additional guidance, assistance, and convenient maintenance services for your vehicle. Thank you for choosing SLANE Electric Scooter. We wish you a long and enjoyable journey filled with comfort and delight.

## Important Notices

- **Special Note:** In case of power supply damage or charging system malfunction, please visit the manufacturer-designated repair shop for replacement and repairs.
- **Rider and Passenger:** The Slane Electric Scooter is designed to carry the rider and has a maximum rated capacity of 2 passengers. Overloading is strictly prohibited.
- **Road Conditions:** The Slane Electric Motorcycle is not suitable for driving on highways.

*Please pay close attention to the critical information highlighted in the following ways:*

**Danger:** Indicates that serious injury or death may occur if instructions are not followed.

**Warning:** Indicates that injury or equipment damage may occur if instructions are not followed.

**Caution:** Draws attention to minor hazards and provides helpful information.

**Environmental Protection:** Indicates the requirement for environmental protection and measures to maintain emission levels. Improper use of electric motorcycles may cause environmental pollution.

Any faults that need handling by authorized service centers or designated repair stations of our company must not be attempted by users themselves. Otherwise, our company shall not be held responsible for any consequences.

This manual shall be a permanent part of the electric motorcycle and must accompany the vehicle upon transfer.

The copyright of this manual belongs to Wuxi SLANE Vehicle Co., Ltd. No reproduction is allowed without the written consent of our company. Violators will be prosecuted.

## Contents

<b>Chapter 1 - Safety Precautions</b> .....	<b>1</b>
<b>Chapter 2 - Riding Operation Instructions</b> .....	<b>2</b>
<b>Chapter 3 - Battery Usage</b> .....	<b>4</b>
<b>Chapter 4 - Charger Usage and Maintenance</b> .....	<b>6</b>
<b>Chapter 5 - Inspection and Routine Maintenance</b> .....	<b>7</b>
<b>Chapter 6 - Introduction of Troubleshooting, Fault Code, and Maintenance Guideline</b> .....	<b>9</b>
<b>Chapter 7 - Main Performance Parameters Table</b> .....	<b>19</b>
<b>Chapter 8 - Electrical Principle Drawing</b> .....	<b>20</b>
<b>Chapter 9 - About Vehicle</b> .....	<b>21</b>
<b>Chapter 10 - After-sales and Warranty</b> .....	<b>28</b>

## Chapter 1 - Safety Precautions

- 1, Before using electric mopeds for the first time, please read the instruction manual carefully, do not lend to people who do not operate electric mopeds to ride.
- 2, Many motorcycle traffic accidents, are due to the driver can not see the motorcycle driver speeding, not according to the rules of the road occurred. Therefore, electric motorcycle drivers should pay attention to:
  - \*Try to wear bright colors dazzling clothing.
  - \* It is strictly prohibited to fight or rush the road.
  - \*Do not get too close to other motor vehicles and avoid driving out of the line of sight of other drivers.
  - \*Obey the traffic rules and don't speed.
  - \* Drive slowly at road intersections and parking lot entrances and exits.
3. When riding electric mopeds, please drive slowly on slippery roads to avoid sudden braking; Please use caution in rainy days, try not to ride in the area where the water depth exceeds the central shaft of the motor, to avoid the motor water.
4. When charging electric moped, it is strictly prohibited to cover the charger shell to ensure ventilation and heat dissipation. The charger is used in doors and beware of rain.
5. Since the majority of serious motorcycle accidents are head injuries, motorcycle drivers should wear a helmet, and must also wear or wear other protective tools such as goggles, boots, gloves, and thick, tight clothing.
- 6, can not use the battery do not dispose at will, please return the abandoned battery to the store, the store will be at the appropriate price to recycle the waste battery.
7. Please go to Slane after-sales service station for the first maintenance in the second month or 300Km after the purchase of the car, and then go to the after-sales service station for regular vehicle maintenance every three months.
8. Please check the vehicle brake system and light, horn before each use of electric mopeds work properly, and check whether the bolt or nut connection fastening place is loose, if loose, please tighten after use, so as to prevent accidents.
9. Do not disassemble or change the vehicle circuit, in any abnormal condition, the user can use the power switch to turn off the vehicle power supply to ensure safety.

**Warning: Modifying the motorcycle or replacing the original device will not ensure the safety, users must strictly abide by the traffic management departments regulations on the use of vehicles.**

## Chapter 2 -Riding Operation Instructions

### Pre-Ride Inspection

Failure to conduct a pre-ride inspection may result in severe personal injury or damage to the electric motorcycle during operation. It is imperative to inspect the electric motorcycle thoroughly before riding.

The following inspection items, requiring only a few minutes, can save you time from unexpected repairs during your journey and ensure safe driving.

N O.	Item	Inspection Contents
1	Tires	Check for proper air pressure and inspect for abnormal conditions or severe wear on the surface
2	Front and Rear Brakes	Ensure reliable operation
3	Horn	Ensure reliable functioning
4	Lighting Fixtures	Ensure reliable operation
5	Instrument Panal	Check if all signal and indicator lights are functioning normally
6	Rearview Mirrors	Ensure they are clean and provide an adequate field of view
7	Handlebars	Check for smooth rotation, free from stiffness or jamming
8	Steering Handle	Ensure smooth steering, free from play, looseness, excessive tightness, or jamming
9	Front and Rear Wheel Axles	Check for loose nuts
10	Rear Fork Fastening Nuts	Check for loose nuts
11	Battery Level	Ensure sufficient charge for the planned travel distance

## Precautions for Riding

- 1.If you are riding an electric motorcycle for the first time, please practice in an open area first, and only proceed to ride on the road after mastering the riding skills.
- 2.When using an electric motorcycle, turn on the switch by flipping it to the  “ON” position. Avoid rapidly twisting the speed control handle.
- 3.The “buzzing” sound emitted during motor startup is normal, indicating efficient magnetic field operation. This sound will disappear as the motor reaches its optimal speed.
- 4.Avoid overloading. For safety, minimize frequent braking and starting. When encountering situations, brake, disconnect power, or decelerate by coasting in advance.
- 5.On wet or slippery roads, reduce speed, avoid sharp turns and sudden braking, maintain a safe following distance, and increase braking distance accordingly.
- 6.When riding at night, ensure headlights are on. Use turn signals and decelerate when turning.
- 7.Be careful in rainy weather. Avoid riding in water deeper than the motor’s axle to prevent its damage. 8.Never ride an electric motorcycle with one hand. Comply with traffic rules and regulations at all times.

## Post-Riding Precautions

- 1.After using the electric motorcycle, turn the switch to the  “OFF” position, disconnect the power, and remove the key (lock the front wheel if equipped).If the electric motorcycle will not be used for an extended period, remember to recharge it periodically.
- 2.Ensure stable support when parking.
- 3.Promptly check the battery level and recharge as necessary to avoid inconvenience during your next ride.
- 4.If lithium-ion batteries are not used for a long time, they should be charged to 50%-80% capacity, removed from the vehicle, and stored in a dry, cool environment. Recharge them every 3 months to maintain battery health.
- 5.After the charger indicator turns from red to green, it indicates trickle charging. Typically, allow an additional half-hour of charging after the green light appears. Battery capacity should be verified by the instrument display.

## Chapter 3 -Battery Usage

### Precautions for Battery Usage

The capacity of the battery will decay with the increase of use time and mileage. Correct use and maintenance can effectively prolong the life of the battery.

#### 1. The battery use method

- (1) When the newly purchased electric motorcycle is used for the first time, please charge the battery less than 10 hours, but not more than 12 hours before driving at the first 7 charges.
- (2) In the driving, if the power is in the red area, it should be charged as soon as possible and excessive discharge is prohibited.
- (3) Each time after use, should check the battery power, please do not use the lowest battery power, develop the habit of timely charging; when the vehicle is placed for a long time, should also be regular (1 month) supplement once, so as to extend the life of the battery.
- (4) The capacity of the battery is affected by the ambient temperature. When the ambient temperature is lower than 0°C, the effective capacity of the battery will drop by 20% -30%, which is a normal phenomenon.

### The correct maintenance method of the battery

- (1) Lead acid battery, no matter how much electricity is consumed, should be replenished in time, which is conducive to extending the service life of the battery.
- (2) When the battery capacity is significantly attenuated, should be timely to the service station for inspection, to determine whether the battery decline is normal and necessary to change the state of the battery through maintenance.
- (3) It is recommended to check and maintain the battery at the Slane after-sales service station every three months to confirm whether the joint is loose and the battery needs to be liquid.
- (4) The electrolyte in the battery will evaporate due to the charging heating. When the liquid level is lower than the liquid level scale line, the battery should be filled with distilled water to the specified liquid level.
- (5) The battery surface should be kept clean and dry to avoid approaching open fire or hot heat source; prohibit sun exposure in high temperature season.
- (6) If the battery surface is severely dirty, wash it with hot water at 60°C.

**pay attention to:**

1. Do not discard waste batteries, so as not to pollute the environment.
2. Waste battery can not be privately processing, Slane company after-sales service station is responsible for recycling.

# How to connect battery

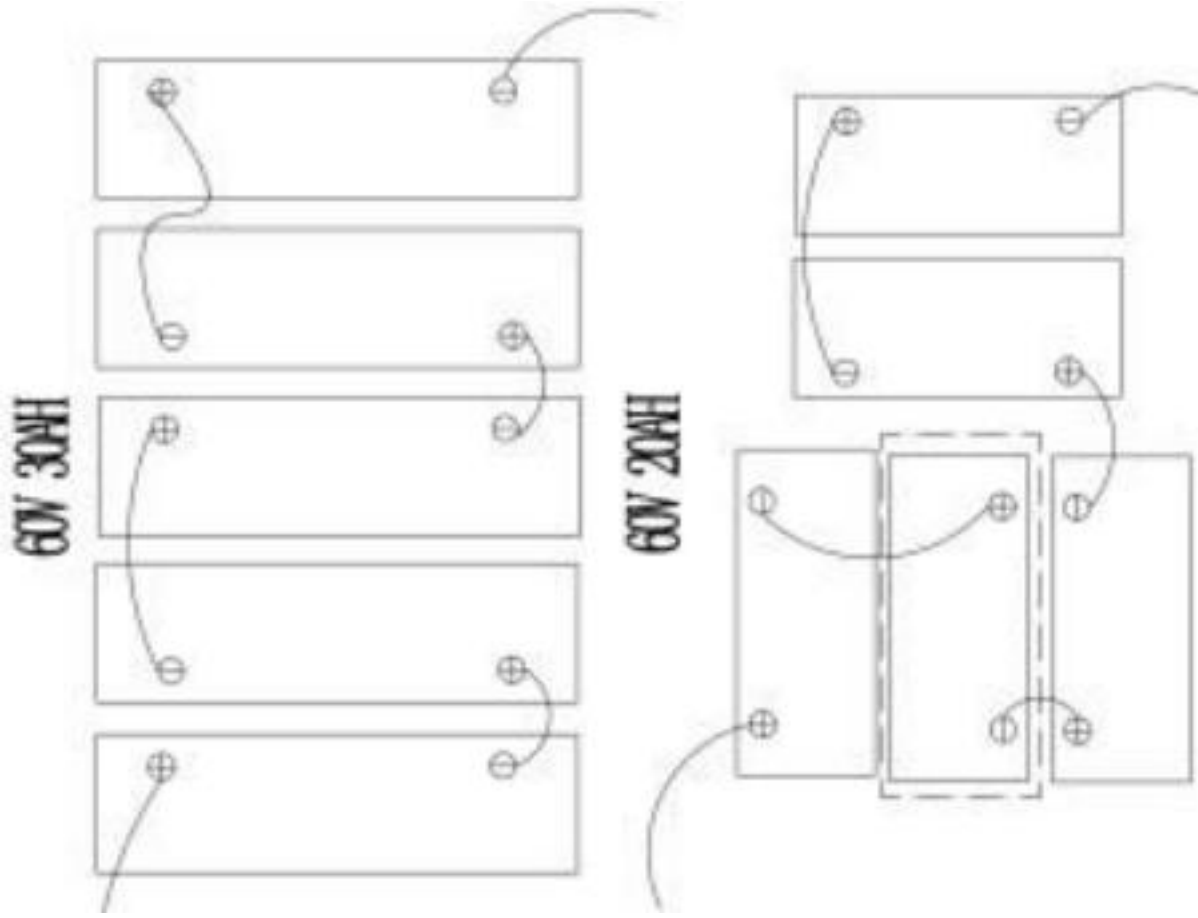

like photo shows

**Note 1:** First connect the open circuit wire (positive pole of the battery) to the positive pole of a single cell, then connect batteries in series with the battery connection wire, and finally connect the negative pole of the battery to the negative pole of the battery. After the connection, cover the cap on the terminal post. Note

**2:** Do not connect the positive and negative poles of the battery incorrectly or short circuit them; do not place metal objects tools on the battery. Before connecting, all electrical switches should be turned off to reduce the risk of sparks during the final connection.



## Chapter 4 -Charger Usage and Maintenance

### Usage Instructions

Connect the charger's output plug securely to the socket of the battery pack to be charged. Then, securely connect the AC plug to the AC outlet, ensuring all connections are correct. The charger will initiate output after self-checking. Once charging is complete, the indicator light will turn green and remain lit. Disconnect the charger's AC plug from the outlet.

### Precautions

- (1) When the parking charge is charging the battery on the electric vehicle, please close the main power switch on the electric vehicle, connect the output of the charger to the charging socket on the electric vehicle, and then connect the input end of the charger to the AC220V power outlet.
- (2) Off vehicle charge in  
When removing the battery from the electric vehicle and charging the battery separately, the charger output terminal first connects to the battery box charging socket, and then the charger input terminal connects to the AC220V power socket.
- (3) When charging, the charger indicator is red. When the indicator turns green, the battery is basically full. At this time, the charger is floating charging state,generally should be continued for 1-2 hours to make the battery charge more full. Total charging time should not exceed for the 12 hours. If the red light still does not turn to the green light after 12 hours, the charging should be stopped, and the charger will be sent to Slane professional after-sales service station for inspection.
- (4) Charging should be carried out in a ventilated and cool place and stay away from flammable and explosive items. During the charging process, it is strictly prohibited to cover any items on the charger. After charging, unplug the charger input power plug, then unplug the charger and battery connection plug.

### Maintenance method of the charger

Carry the charger with the vehicle, should wrap the buffer to avoid sulfur collision and vibration caused by turbulence.

## Chapter 5 -Inspection and Routine Maintenance

No.	Inspection & Maintenance Item	Contents of Inspection & Maintenance	Inspection Interval	Troubleshooting method
1	Tires	Tire pressure, wear level	Daily	Inflate / replace tires/ Patch
2	Braking System	Brake distance, cables, brake pads, overload protection switch	Weekly	Replace brake or Top up fluid
3	Horn	Wiring solder joints and insulation	Weekly	Replace
4	Rearview Mirrors	Viewing angle, range, nut tightness	Weekly	examine and repair
5	Lighting Fixtures	Beam position, angle, wiring, and insulation	Weekly	Replace
6	Instrument Panal	Instrument indications, wiring	Weekly	examine and repair
7	Fasteners	Nut tightness	Weekly	examine and repair
8	Speed Control Handle	Travel position	Weekly	examine and repair
9	Front & Rear Hubs	Total runout, radial runout, cracks	Weekly	examine and repair
10	Handlebars	Rotation flexibility	Weekly	examine and repair
11	Frame & Rear Fork	Welding points, nut tightness	Weekly	examine and repair
12	Front Fork	Fasteners, steering bearings	Weekly	examine and repair
13	Shock Absorbers	Shock absorber travel and other abnormalities	Weekly	examine and repair
14	Locks	Functional inspection	Weekly	examine and repair
15	Battery	Voltage balancing, ensuring normal charging and discharging (completed in the charging cabinet)		examine and repair
16	Motor	End caps, bearings, Hall sensors, signal wires, motor wiring, and insulation of motor housing		examine and repair
17	Controller	Under voltage and over current protection functions		examine and repair
18	Charger	Charging current and voltage		examine and repair
19	Main Cable	Soldering points, insulation, and wear condition		examine and repair

## Note

1. Regularly apply an appropriate amount of lubricating grease to the front axle, rear axle, and middle axle.
2. Faults caused by failure to conduct regular professional inspections are not covered under warranty.
3. Caution: Under conditions of frequent heavy loads, high-speed driving, bumpy roads, and uphill climbs, maintenance intervals should be shortened.

## Adjustment and Inspection of Speed Control Handle

1. Check the left and right rotation positions of the speed control handle to ensure smooth rotation from fully open to fully closed. Ensure there are no frictions or obstructions that hinder automatic reset.
2. Verify the free play of the speed control handle. The standard free play for handle rotation should be approximately 2-6mm. To adjust, loosen the locknut and turn the screw clockwise to increase the free play or counterclockwise to decrease it. After adjustment, tighten the locknut securely.

## Chapter 6 - Introduction of Troubleshooting And Fault Code

### Common faults and troubleshooting methods

**Note: For other failures, please go to the after-sales service station for inspection. Do not modify it privately. Privately changing the circuit will to circuit crossover, wear and tear leading to short circuit and fire.**

Fault phenomenon	Fault cause	Troubleshooting method
Turn on the power supply without a power supply indication	<ol style="list-style-type: none"> <li>1. Insurance fuse blown</li> <li>2. Poor connection between power plug and battery socket</li> </ol>	<ol style="list-style-type: none"> <li>1. Check if the fuse needs to be replaced</li> <li>2. Check for looseness</li> </ol>
Turn on the power supply to turn the speed control knob, but the motor does not start	<ol style="list-style-type: none"> <li>1. Low battery voltage</li> <li>2. Squeezing the brake lever halfway or pressing the brake pedal, causing the power-off switch to</li> <li>3. Motor lock not opened</li> </ol>	<ol style="list-style-type: none"> <li>1. Give the battery a full charge.</li> <li>2. Do not hold the brake lever or press the brake pedal starting.</li> <li>3. Open the motor lock before use.</li> </ol>
Slow to exercise speed or insufficient driving range	<ol style="list-style-type: none"> <li>1. Low battery voltage</li> <li>2. Insufficient tire pressure</li> <li>3. Frequent braking, starting, and overloading</li> <li>4. Battery aging or normal degradation</li> <li>5. Low environmental temperature, reduced battery capacity</li> </ol>	<ol style="list-style-type: none"> <li>1. Charge and check if the plug is making poor contact.</li> <li>2. Check the air pressure before each use.</li> <li>3. Develop good driving habits</li> <li>4. Replace the battery.</li> <li>5. This is a normal phenomenon.</li> </ol>
Battery not charging	<ol style="list-style-type: none"> <li>1. The contact between the charger plug and the battery socket is poor.</li> <li>2. The charger is broken.</li> </ol>	<ol style="list-style-type: none"> <li>1. Check if the outlet is loose.</li> <li>2. Replace the charger.</li> </ol>
The vehicle has an unusual noise	<ol style="list-style-type: none"> <li>1. Loose screws in various parts</li> <li>2. Wear between moving and stationary parts</li> <li>3. Bearing damage or fracture due to oil</li> </ol>	<ol style="list-style-type: none"> <li>1. Tighten screws in all parts.</li> <li>2. Check if any part is worn.</li> <li>3. Lubricate replace the bearing.</li> </ol>
The brakes are not working well	<ol style="list-style-type: none"> <li>1. Brake shoes or discs worn out</li> <li>2. Brake cable displaced</li> <li>3. Low brake fluid level</li> </ol>	<ol style="list-style-type: none"> <li>1. Replace brake shoes or brake discs</li> <li>2. Adjust the brake cable</li> <li>3. Top up the brake fluid</li> </ol>

## Speedometer Fault Code

Fault Code	Fault Description
86	GPS fault
87	Network failure_GPRS
88	Discharging low temperature protection
89	Charging low temperature protection
90	Discharging over-current protection
91	Discharging high temperature protection
92	Charge saturation protection
93	Over current protection/Over current fault
95	Handlebar fault
96	Motor phase loss fault/Motor Hall sensor fault
97	MOS FET fault/drive fault
98	Over voltage fault/Over temperature fault/ Under voltage fault/Motor stall fault
100	Motor over-temperature failure
101	Bluetooth fault
103	Ambient temperature failure
104	Self-inspection fault
105	Discharging short circuit protection

Fault Code	Fault Description
106	Charging overheating protection
107	Battery low-voltage protection
108	Battery pack opening circuit
109	MOS overheat protection/MOS failure
110	Temperature sensor fault
111	Single cell voltage abnormality
112	D fault/ EOL alarm
113	Hardware fault
114	Output voltage high
115	Output voltage low
116	Output over current/charger low temperature
117	Charger high temperature
119	Hardware fault
120	Communication fault
520	Tire pressure status_low_front wheel
521	Tire pressure status_high_front wheel
522	Tire leakage_front wheel
523	Low power_front wheel
524	Signal status_poor_front wheel
525	Tire temperature_high_front wheel
526	Tire pressure status_low_rear wheel
527	Tire pressure status_high_rear wheel
528	Tire leakage_rear wheel

529	Low power_rear wheel
Fault Code	Fault Description
530	Signal status_poor_rear wheel
531	Wheeltemperature_high_rear wheel

**In case of above faults, please come to SLANE repair service shop for repairing as early as possible.**

### Maintenance Guideline

- 1. perform the first maintenance after 1,000 km or riding for 3 months.
- 2. After the first maintenance , it is recommended to carry out maintenance of your vehicle every 2,000 km or riding for 6 months.



performed by:

Dealer stamp here

Date: \_\_\_\_\_ Mileage: \_\_\_\_\_

Executed maintenance:



**1<sup>st</sup> Maintenance**

Performed by:

Dealer stamp here

Date: \_\_\_\_\_ Mileage: \_\_\_\_\_

Executed maintenance: \_\_\_\_\_

---

---

---

---

---

---

---

---

**2<sup>nd</sup> Maintenance**

Performed by:

Dealer stamp here

Date: \_\_\_\_\_ Mileage: \_\_\_\_\_

Executed maintenance: \_\_\_\_\_

---

---

---

---

---

---

---

---

**3<sup>rd</sup> Maintenance**

Performed by:

Dealer stamp here

Date: \_\_\_\_\_ Mileage: \_\_\_\_\_

Executed maintenance: \_\_\_\_\_

---

---

---

---

---

---

---

---

**4<sup>th</sup> Maintenance**

Performed by:

Dealer stamp here

Date: \_\_\_\_\_ Mileage: \_\_\_\_\_

Executed maintenance: \_\_\_\_\_

---

---

---

---

---

---

---

---

**5<sup>th</sup> Maintenance**

Performed by:

Dealer stamp here

Date: \_\_\_\_\_ Mileage: \_\_\_\_\_

Executed maintenance: \_\_\_\_\_

---

---

---

---

---

---

---

---

**6<sup>th</sup> Maintenance**

Performed by:

Dealer stamp here

Date: \_\_\_\_\_ Mileage: \_\_\_\_\_

Executed maintenance: \_\_\_\_\_

---

---

---

---

---

---

---

---

**7<sup>th</sup> Maintenance**

Performed by:

Dealer stamp here

Date: \_\_\_\_\_ Mileage: \_\_\_\_\_

Executed maintenance: \_\_\_\_\_

---

---

---

---

---

---

---

---

**8<sup>th</sup> Maintenance**

Performed by:

Dealer stamp here

Date: \_\_\_\_\_ Mileage: \_\_\_\_\_

Executed maintenance: \_\_\_\_\_

---

---

---

---

---

---

---

---

## Dealer inspection scheme

#	Inspection type	Project	eScooter Buying	The third month	The ninth month
			0KM	1000KM	3000KM
1	visual inspection	vehicle appearance inspection	✓	✓	✓
2	Mechanical structure inspection	Handlebar steering inspection	✓	✓	✓
3		Fastening of core parts		✓	✓
4		Lubrication of core components		✓	✓
5	Brake system inspection	Front brake check	✓	✓	✓
6		Rear brake check	✓	✓	✓
7		Tyre pressure check	✓	✓	✓
8		Disc brake check		✓	✓
9	Electrical system inspection	Automated lightning system and core components	✓	✓	✓
10		Firmware update check	✓	✓	✓

## Chapter 7 - Main Performance Parameters Table

Item	Parameters	Item	Parameters
Vehicle trademark	SLANE	Motor model	72V1500W
Vehicle model	RC	motor type	Permanent magnet, DC, brushless motor
Dimensions (mm)	1930*700* 1125	rated voltage (V)	72
wheelbase (mm)	1270	Rated rotation speed (r/min)	412
Minimum ground clearance (mm)	N.A.	power rating (W)	1500
Mass in running order(kg)	65	Rated torque (N. m)	34.8
Rated passenger capacity (person)	2	Battery type	Lead acid battery
Actual mass (kg)	177	accumulator capacity	72V 20Ah
Brake type	Front :disc    Rear:drum	Controller under voltage protection value (V)	52.5±1
Brake control type	Front: hand brake / Rear: hand brake	Controller over current protection value (A)	35±1
tyre size	(Front / rear)   100/70-12	Charger input power supply voltage and frequency	220V/50Hz
Tire pressure (front / rear) (kPa)	225/225	Headlight specifications	12V LED
Top vehicle speed (km/h)	45	Front lamp specifications	12V LED
Energy consumption rate (Wh / km)	47	Steering signal light specification	12V LED
Driving range (km)	55	Rear position lamp / brake lamp specification	12V LED
climbing capacity (°)	25	Fuse specifications	10A

## Chapter 8 - Electrical Principle Drawing

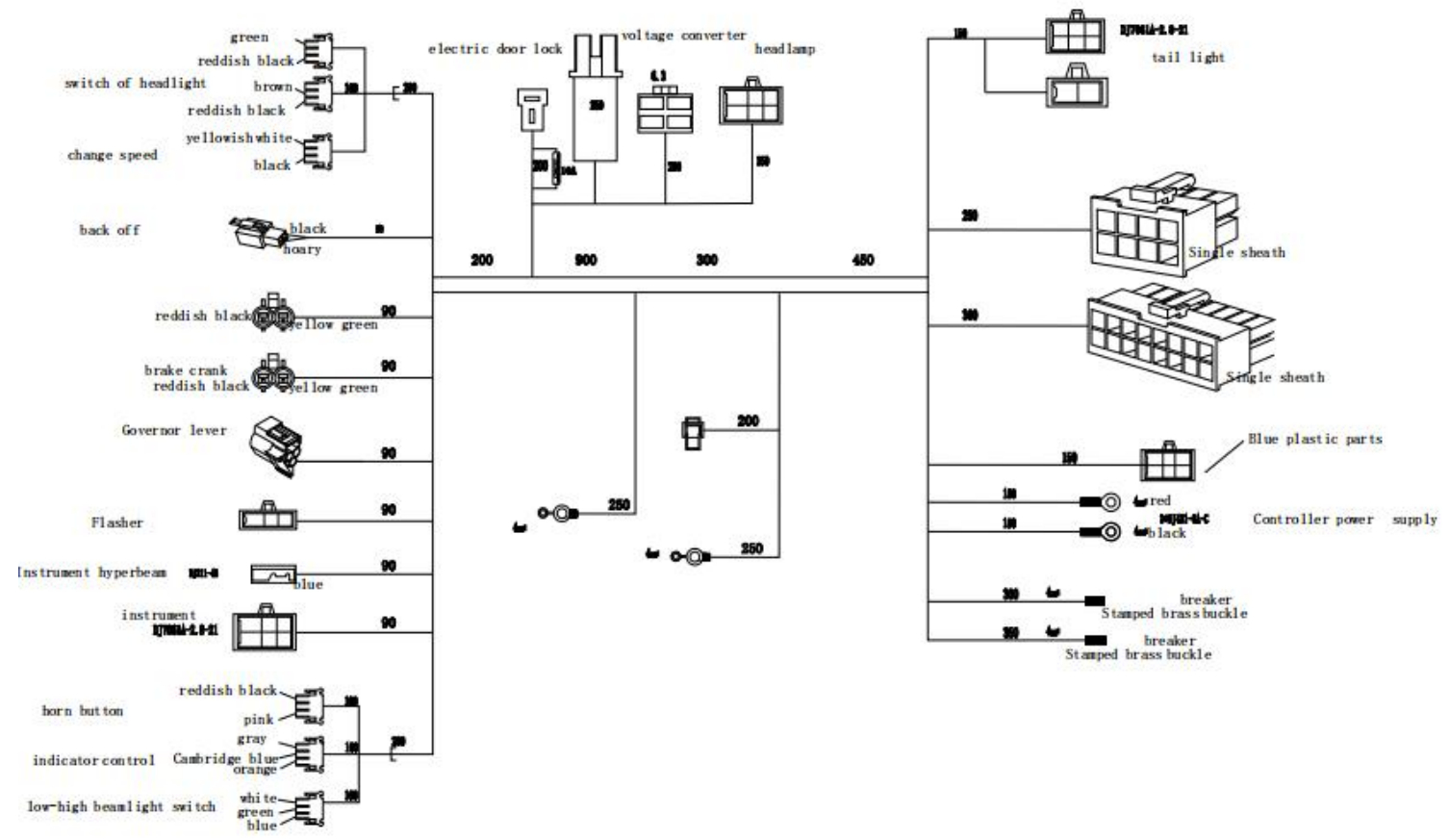

# Chapter 9 - About Vehicle

## Vehicle Structure Diagram



- 1 Front wheel
- 2 Front brake
- 3 Front mudguard
- 4 Front shock absorber
- 5 Headlamp / front lamp
- 6 Front panel
- 7 Front turning signal
- 8 Mirror
- 9 Rear brake handle
- 10 Battery
- 11 Seat cushion
- 12 Shelves
- 13 Left and right side plate
- 14 Flat fork protection plate
- 15 Parking rack
- 16 Side support
- 17 Left and right guard
- 18 Frame





- 19. Rear wheel
- 20. Side reflector
- 21. Rear fender plate
- 22. Rear license plate
- 23. Rear reflector
- 24. Taillight
- 25. Switch combo
- 26. Speedometer
- 27. Front brake handle
- 28. Speed throttle
- 29. Front tool box
- 30. VIN number
- 31. Battery box
- 32. Rear brake

## Vehicle Identification

Vehicle identification number: ☆□□□□□□□□□□□□□□□□☆

Please record the vehicle identification number in the space provided. This will help you order spare parts from us. Or for tracking purposes if your vehicle is stolen.

The vehicle identification number (VIN) is printed on the right side of the head tube of the frame. It is generally composed of 17 letters and numbers. The number is remembered by the user, and the position is shown in the figure:

- 1) The motorcycle frame number is engraved at the ① point in the middle of the main bending beam of the car frame.
- 2) The vehicle nameplate is riveted at the ② on the end bend sign bracket in the middle of the frame.
- 3) The motor number is engraved at ③ at the end of the motor hub.



## The electric door lock switch

OFF position: The entire circuit is open, the motor cannot operate, and the key can be removed.

ON position: The entire circuit is, the motor and lights and signaling devices can operate, and the key cannot be removed.

Headlock (LOCK) position: The key is pressed to the left to locked position, the head is locked, the vehicle cannot steer, the entire circuit is closed, the motor cannot operate, and the key can be removed.



### The Instrument and Indicator Light

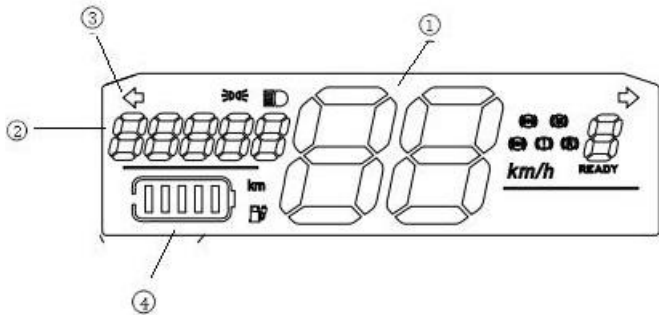

- ① Speedometer - Indicates the motorcycle's driving speed (km/h).
- ② Odometer - Indicates the motorcycle's driving distance (km).
- ③ Turn Signal Indicator.
- ④ Battery Charge Indicator - Shows the level of charge in the battery. If the needle points to the H area it means the battery is fully charged; if it points to the "L" red area, it means the battery is low on charge and needs to be recharged soon.

### The left hand controls the operating system

- ① Horn Switch (🔊) - Press the horn switch button, the horn sounds.
- ② Turn Signal Switch - When turning left, move switch to the " ← " position; when turning right, move the switch to the " → " position. when the switch is in the " ← " or " → ", the turn signal lights remain on, the front and rear turn lights on the (left or right) side and the turn signal indicator on the instrument panel light simultaneously. When the switch is in the middle position, the light indication is canceled.
- ③ Light switch - When the right handlebar switch is set to the "on" position, the headlights, taillights, front and position lights, and instrument panel lights come on. When the left handlebar switch is set to the "three O" position, it is in low beam mode when set to the "EO" position, it is in high beam mode, and the high beam indicator on the instrument panel lights up. When the right handle switch is set to other positions, the lights and light indicators are turned off.
- ④ Front brake lever - When the front brake lever is squeezed, the front is braked, and the rear brake light comes on at this time.

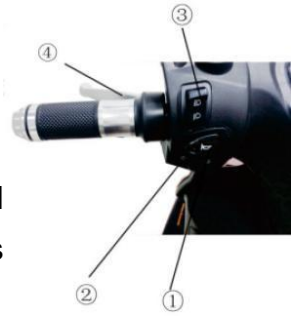

### The right hand controls the operating system

- ① Horn Switch (🔊) - When the horn switch button is pressed, the horn sounds.
- ② Lighting Switch - When the switch is set to "●" position, the front and rear lights are off. When the switch is set to the "☀" position, the position lights (inside the headlights tail lights, and instrument panel lights come on. When the switch is set to the "☀" position, in addition to maintaining the above signals, the headlights come. The high and low beams are controlled by the left handlebar switch.



- ③ Throttle - Used to control the vehicle's speed. To accelerate, turn throttle towards you; to decelerate, turn it away from you.
- ④ Front Brake Lever - When the front brake lever is squeezed, the front wheel braked, and the rear brake light comes on.

### The Main Power Switch

The main power switch is located in the rear storage compartment under the seat. First, open the seat lock, lift the cushion, and switch the power switch to the "ON" position, indicating that the whole vehicle is powered; switch the power switch to the "OFF" position indicating that the whole vehicle is powered off.



### Inspection of Front and Rear Brakes

The front brake master cylinder is located on the right side of the steering handle, and the rear brake master cylinder is located on the left side of the steering handle. The part of the brake cylinder that contacts the brake disc for friction braking is the disc brake shoe. If the disc brake shoe is worn to the wear limit, it must be replaced with a new one.

Park the model on a level surface and check the oil level shown in the oil level windows on the front and rear brake master cylinders. If the oil level has reached one-third of the oil mirror hole, it means the oil level has reached the lower limit and the brake fluid should be replenished in time. When adding brake fluid, loosen the screws and remove the pump cover to add brake fluid.

**Danger:** Brake fluid should be selected strictly according to regulations and cannot be replaced by the engine oil, otherwise it will affect the braking effect. Brake fluid can cause skin or eye inflammation. Once contacted, please wash with water immediately.

### Adjustment of Front and Rear Brakes

The front wheel of this vehicle uses a disc brake, and the rear wheel uses a drum brake. Before driving, the brakes should be, and the inspection items are as follows:

#### 1. Adjustment of the front brake

- (1) Support the motorcycle with the main stand.
- (2) Measure distance ① from the front brake lever to the point where the front brake is about to engage, which is the free travel of 5-10mm
- (3) This motorcycle uses a hydraulic disc brake system. When the brake pads wear out, the brake fluid level will drop.
- (4) This brake mechanism not need adjustment, but it requires regular checking of the brake fluid level and the wear condition of the pads. It is necessary to frequently check and ensure that the system has no leaks. If the free travel of the brake lever is too large



and the wear of the brake pads is not beyond the limit, it means that has entered the system, which must be bled. Please entrust this service to the Slane after-sales service station.

(5) Check the brake pads see if they are worn down to the limit mark ②.

**2. Adjustment of the Rear Brake**

- (1) Support the motorcycle with the main stand.
- (2) Measure the distance the rear brake lever① moves before it starts to brake, which should be a free travel of 10mm~20mm.
- (3) If adjustment is needed, the rear brake lever nut ② to the appropriate position.
- (4) Apply the brakes several times, and when you release the brake, check that the rear can rotate freely.



**Tire**

**Warning: After adjusting the free travel, make sure that the adjusting nut slots are seated on the brake safety pins.**

To regularly check the pressure and pattern of the tire, in order to ensure maximum safety and longer service life, the tire should be regularly checked out.

**1. Tire pressure check**

If the tire pressure is too low, it will not only accelerate the wear of the tire but also severely affect stability of the motorcycle, making it difficult to turn. However, if the tire pressure is too high, it will reduce the contact area between the tire and the ground causing the wheel to slip or even lose control. When adjusting the tire pressure, it should be done when the tire is cool.

Project	Tire Pressure
Front Wheels	225±10Kpa
Rear Wheels	225±10Kpa



## 2. Tire tread inspection

When tire wear is too severe, the stability of the motorcycle will be severely reduced, which may cause loss of control. the center tread depth of the front tire is reduced to less than 1.6mm and the center tread depth of the rear tire is reduced to less than 2mm, the tires should be replaced.

**Caution :** Using excessively worn tires is extremely dangerous and will affect the indexing, stability, steering and handling performance.

**Caution :** Before driving, check tire pressure. Check tires for cuts, nails or other sharp objects embedded. Check wheels for dents or deformations. If any damage is found, please have them repaired or replaced at our service station.

**Caution :** Incorrect tire pressure may cause abnormal tread wear, which may lead to unsafe accidents. Insufficient tire pressure may cause tire damage or detachment from the wheel hub.

Replace the tire when the tread in the center of the tire reaches the following limits.

## Replacement of Fuses

The fuses used in the vehicle often blow out, which is usually caused by a short circuit or overload of the electrical system. Please have the station staff inspect and repair it. When replacing the fuse, open the fuse box, remove the old fuse, replace it with a new fuse of the same specification(10A for this vehicle), and then reinstall the fuse box.

**Warning:**

1. When inspecting or replacing the fuse, turn off the master switch (turn the key to the  position) first to short circuit.
2. When replacing the fuse, make sure the specifications are the same and do not use any other conductive materials as substitutes

## Replacement of

## the light

The specifications of the light bulbs used in each luminaire are shown in the following table. When replacing light bulbs be sure to use bulbs with the same specifications. Using light bulbs with different specifications may cause system overload and premature damage to the bulbs.

headlamp	12VLED	Rear turn signal	12VLED
The front lamp	12VLED	Rear light brake light	12VLED
front directional	12VLED	gauge lamp	12VLED

## Chapter 10 - After-sales and Warranty

Dear User:

Thank you for purchasing our company's electric motorcycle. In order to effectively protect your legal rights and interests, for our convenience in fulfilling the three-warranty obligations and responsibilities, please keep the warranty card properly. With the card and the purchase invoice, you can enjoy the-warranty service at the sales unit and the Slane after-sales service station. The three-warranty principle is as follows:

1. When you purchase the RC, you can request the sales staff to provide the correct usage method and maintenance matters, and provide an effective invoice and warranty card, as well as the address and number of the warranty unit.
2. Users should use the product correctly according to the product manual. According to the "Consumer Rights Protection Law of the People Republic of China" and the national three-warranty regulations for products, any performance failure caused by product quality will be fulfilled by our company under the three-warranty.
3. For vehicle damage or performance failure caused by product quality or defects, we provide "warranty" service. During the warranty period, we do bear any related indirect losses or responsibilities. During the warranty period, regardless of which parts are replaced, the warranty period is accumulated on the original vehicle.
4. Users are advised to go to the Slane professional after-sales service station for the first maintenance and care in the second month after purchasing the vehicle, and then three months thereafter. The free service content during the three-warranty period is as follows: The whole vehicle warranty period is one year from the date of purchase ( on the invoice) or 6000 kilometers of driving, and the three-warranty is invalid if either is exceeded; within the three-warranty range and the effective life cycle of the vehicle (10 years or 50,000 kilometers), the company provides original factory parts and paid services.

## The whole vehicle regular maintenance

In addition to the normal use of the inspection, the vehicle also needs regular maintenance and maintenance. The car should be maintained for the first time in the second month. After that, it is recommended to go to the Slane professional after-sales service station for comprehensive inspection and maintenance every three months to evaluate the performance of the vehicle. The maintenance items are as follows:

No.	inspection item	scope of examination
<b>Routine safety checks</b>		
1	Tyre inspection	Tire pressure value, tire wear degree
2	Brake system inspection	Braking free travel, brake line, brake pads and brake disc wear, Brake power switch
3	The horn check	Line solder joints and insulation
4	Mirror check	Hold the rear viewing angle, range, lenses, and screws
5	Inspection of various lamps and lanterns	Installation position, irradiation Angle, line and insulation
6	Meter check	Instrument indication and wiring
7	Fastener inspection	Tighten the nuts and bolts
8	Speed and turn to check	Schedule location
<b>Structural inspection</b>		
1	Front and rear wheel examination	End jump, path jump, crack, deformation
2	The handlebars check	Rotation condition, rotation range
3	Frame, rear level and righteousness inspection	Fighten all welding points and nuts



4	Check again before	Tightening condition, eight-piece bowl, bearings
5	Check of the front and rear shock absorber	Check the damping stroke and seal inspection
6	Lock check	Action flexibility, assembly and adjustment
<b>Important parts</b>		
1	Battery inspection	Voltage equalization, electrolyte, solder joints, insulation
2	Motor inspection	End cover, bearing, hall, signal line, motor line, case insulation
3	Controller check	Under voltage and over current protection
4	Charger inspection	Charging current, charging voltage
5	Main beam inspection	Line solder joints, insulation and wear condition

## Vehicle parts warranty period and scope

1. For the frame and rear fork, the warranty period for the following conditions is 5 years (all warranty periods are calculated from the date of shipment):
  - 1.1. 1. Natural detachment, welding failure, or fracture.
  - 1.2. 2. Natural deformation, fracture, or quality issues caused by manufacturing defects.
2. For the motor, the warranty period for the following conditions is 30 months:
  - 2.1. 1. Coil burnout or magnet degradation, detachment.
  - 2.2. 2. Cracking of the housing, hub, or motor shaft fracture.
3. Other components have a warranty period of 15 months.
4. Tires, lights, plastic parts, brake pads, disc brake discs, fuses, chains, and easily damaged bearings are not within the warranty scope.
5. Electronic control products not listed in this document, experiencing performance failure due to manufacturing defects and irreparable, have a warranty period of 15 months.
6. The following conditions are not covered by the warranty terms:
  - 6.1. 1. Malfunctions caused by the user not following the user manual for correct usage, maintenance, and adjustments.
  - 6.2. 2. Damage caused by smoking, drugs, chemical corrosion, or uncontrollable factors such as earthquakes, typhoons, fires, and floods.
  - 6.3. 3. Users not repairing at designated maintenance centers, self-modification, disassembly, or component damage.
  - 6.4. 4. Damage to other components caused by the use of non-original parts or unauthorized modifications to the circuit and configuration.
  - 6.5. 5. Malfunctions caused by collisions, falls, overloading, speeding, and other human factors.
7. Lead acid battery have a warranty period of 12 months.





